

KEECH 6-SERIES KEESHARP™ GET SYSTEM

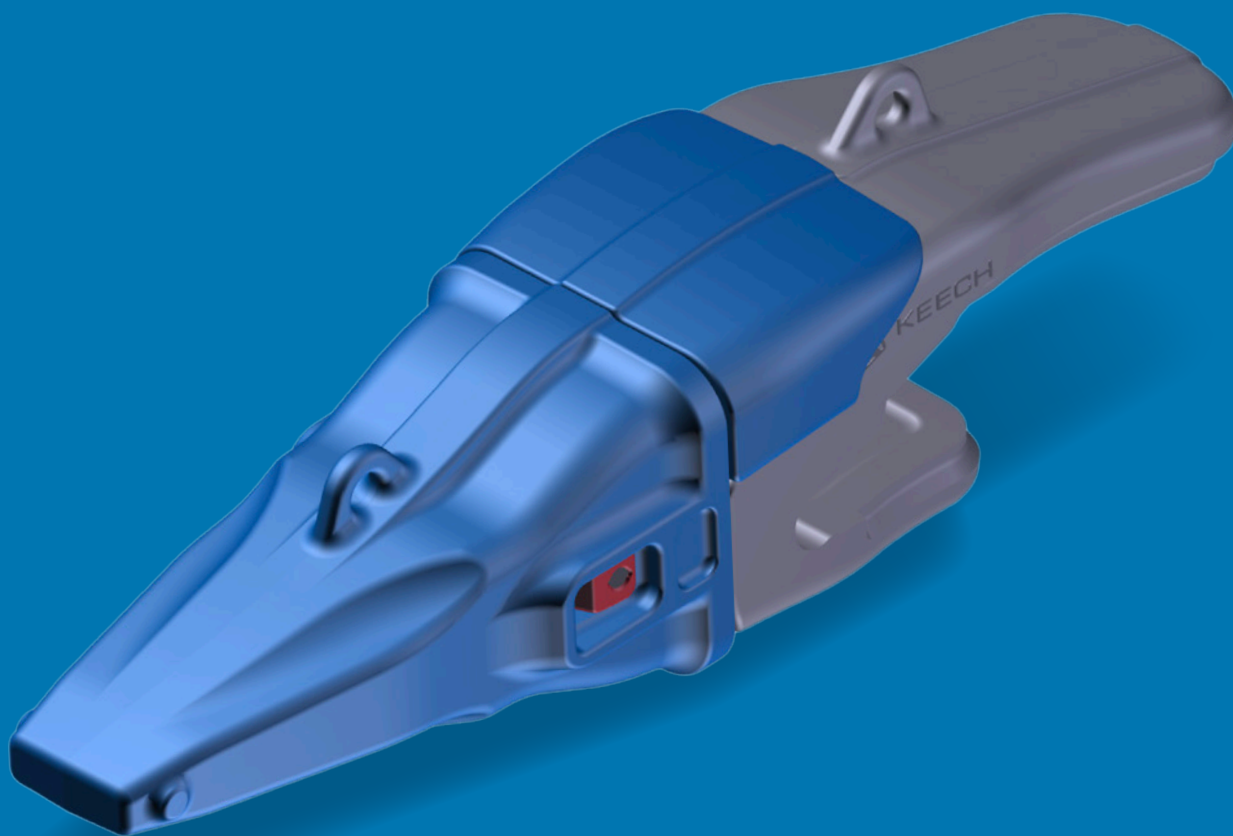

JANUARY 2019

**Product
Information
Brochure**



KEESHARP™ GET SYSTEM

1 INTEGRATED WEAR CAP

- Mechanically attached
- Retained by tooth
- Reduced wear
- Reduced downtime

2 NEW NOSE DESIGN

- Stronger
- Improved fitment
- Larger load bearing area
- Increased retainer strength
- Easier maintenance
- Increases machine uptime and productivity

3 NEW SUPERIOR STEEL

- Abrasion resistant
- Improved wear life
- Reduced downtime costs

4 INCREASED STRENGTH

- Can withstand peak/impact loads
- Higher reliability
- Longer life
- Resistant to wear and breakages

5 DYNAMIC PROFILE

- Increased penetration
- Better digging capacity
- Reduces fuel usage
- Saves time and money

When you need to keep your machines working and productivity high, rely on the proven advantages of a Keesharp™ system, only from Keech. Keesharp's™ light weight, self-sharpening design is made from Keech's new superior **KS** steel, making it tougher, longer lasting and more reliable. Keesharp™ bucket teeth and bucket edge systems are available for a range of machine sizes from 90 to 360 tonnes. Ideal for a variety of applications where you need to maintain bucket availability, teeth are quickly and easily replaced using the patented Keelock™ system. With a completely hammerless, balanced design Keesharp™ is sought after for its longer lasting properties, increased strength and easy on/easy off operation.

Test proven benefits of the Keesharp™ GET system include:

- Increased digging load capacity
- Increased load bearing
- Extended operational life
- Increased nose strength by 30%
- Increased safety margins



6-SERIES

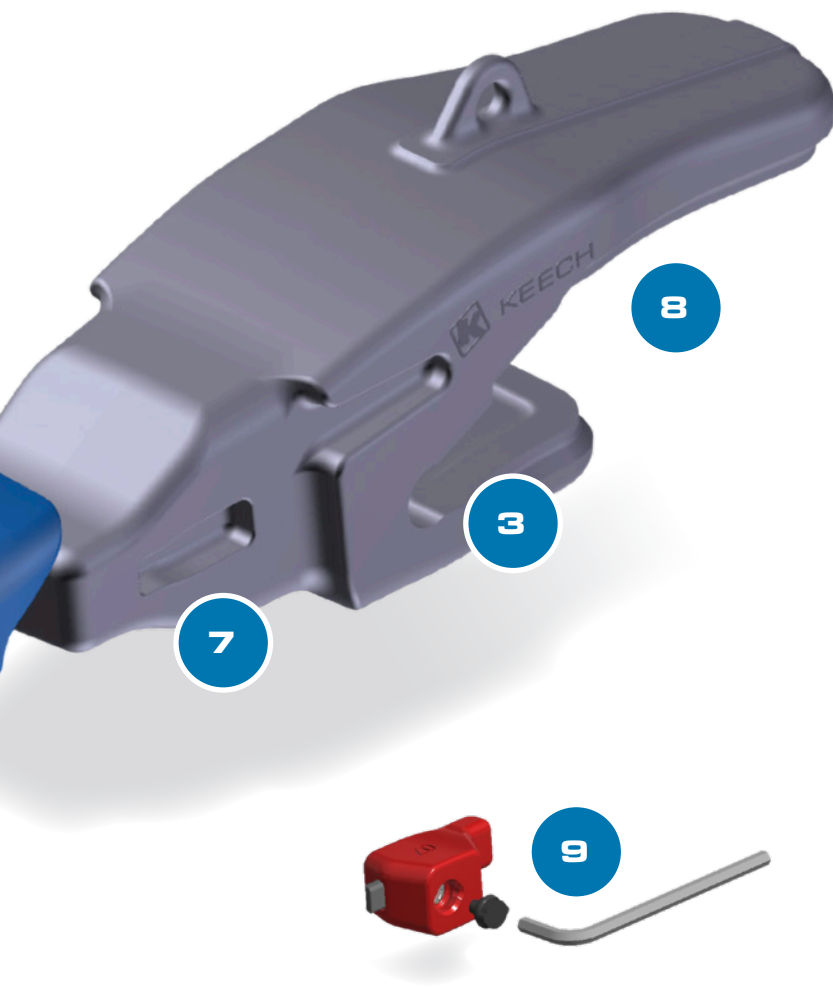

- 6 FLOW DYNAMICS INCORPORATED**
 - Efficient digging
 - Stay Sharp self-sharpening profile in service
- 7 REINFORCED BOX SECTION**
 - Withstands higher impacts
 - Suitable for harsh digging conditions
- 8 PRODUCT VALIDATED THROUGH DESTRUCTIVE TESTS**
 - Verified safety factors
 - Strong and reliable
 - Longer lasting
- 9 PATENTED KEELOCK™ SYSTEM**
 - One piece
 - Completely hammerless
 - Fast changeout
 - Safe and secure
 - Less downtime
 - Less maintenance

Keesharp™ 6-series GET is available in 4 sizes to suit all popular makes and models of excavators and wheel loaders.



KEELOCK™ RETENTION SYSTEM

1 RAPID CHANGE OUT

- Extremely fast
- Tool-less installation in a matter of seconds
- Hammerless system
- Safe & secure
- Reduced downtime costs

2 ONE PIECE RETAINER

- No assembly required
- No nuts, bolts or threads
- Tool-less installation

3 RETROFIT

Compatible with all Keech GET Systems

4 TAPERED FACES

- Easy installation & removal
- Increased safety

5 TOOL-LESS INSTALLATION

Keelock™ can be installed in an instant, no tools required. Simply push into position

6 SECURE SYSTEM

Lock extends securing Keelock™ into position

7 RAPID REMOVAL

Compatible with existing tools for easy removal

Introducing the revolutionary new tool-less installation GET retainer, the patented Keelock™ system.

Keelock™ has removed the opportunity for thread corrosion and assembly difficulties by eliminating nuts, bolts and threads. Keelock™ is an **extremely fast, hammerless, safe and efficient system** that is compatible with all existing Keech GET. With GET change out occurring as often as every 40 hours, Keelock™ has been designed to **save customers thousands of dollars in lost revenue**. Keelock™ can be installed in an instant and removed in less than a quarter of the time required by other systems.

Field tested for all applications on all types of machines, Keelock™ has proven its worth as a productivity booster.

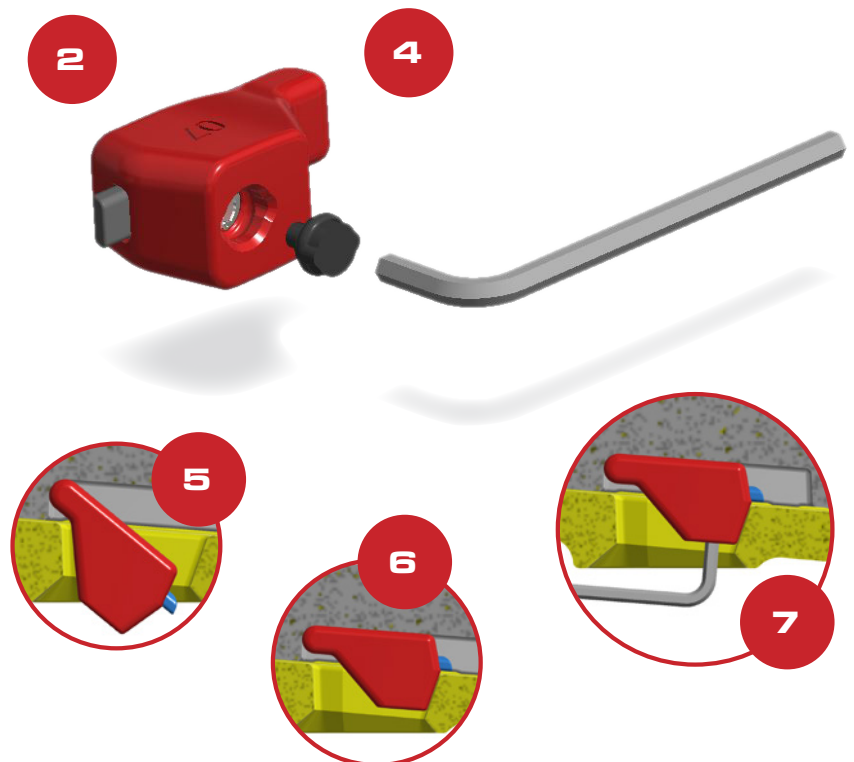

KEESHARP™ GET WITH KEELock™ RETAINING SYSTEM

Keesh 6-Series Keesharp™ GET System covers all applications and various lip configurations. Also available are additional Keesh lip and wing shrouds.

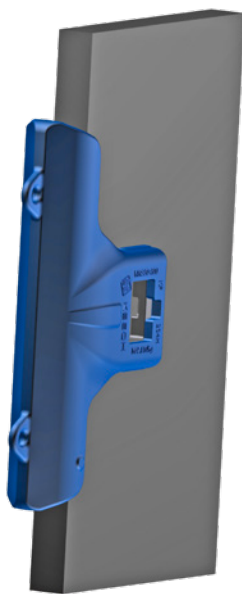
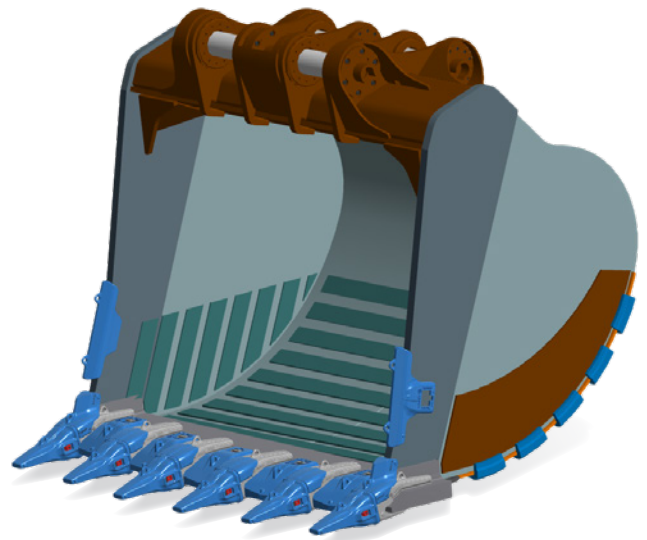
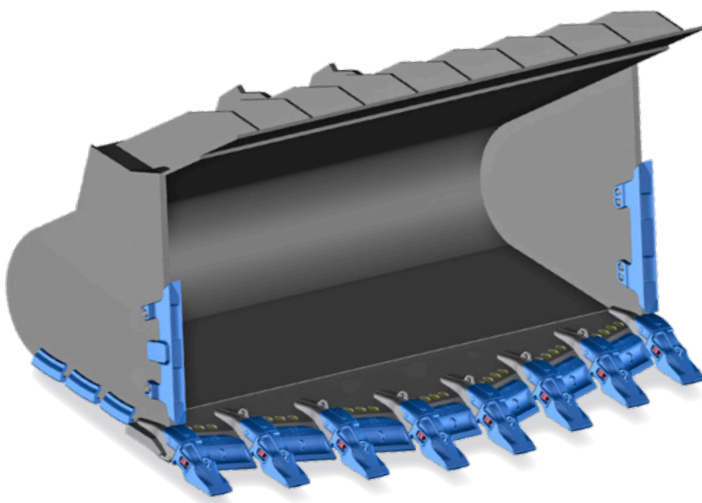

WING SHROUD



LIP SHROUD

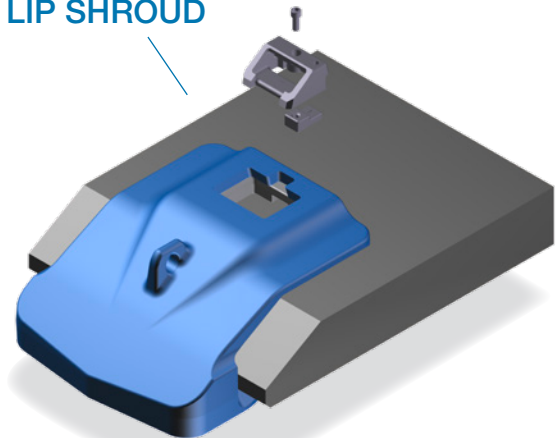

EXCAVATORS



From open pit mining and digging to construction and earthmoving, Keesharp™ offers a range of point styles and sizes to suit applications from general purpose through to heavy duty high abrasion conditions. The specialised design of the Keesharp™ tooth profile means it becomes even sharper with wear, increasing efficiency with use and providing a longer life than its competitors.

TOOTH STYLES

HEAVY PENETRATION

HP

Sizes:

627
637
647
657

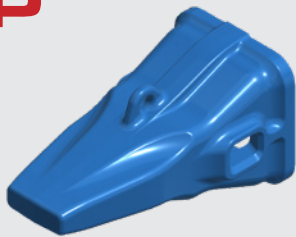

LONG PENETRATION

LP

Sizes:

627
637
647
657

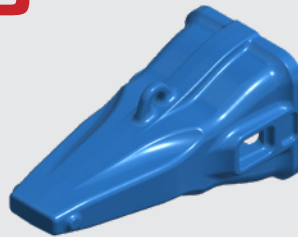

EXTRA PENETRATION

XP

Sizes:

627
637
647
657

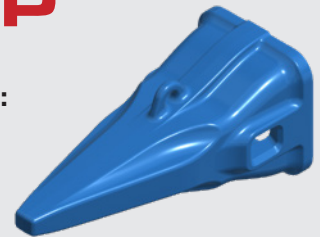

WHEEL LOADERS



TOOTH STYLES

LOADER HEAVY PENETRATION

LHP

Sizes:

627
637
647
657

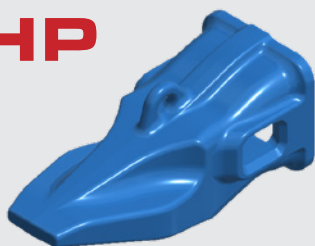

LOADER HEAVY ABRASION

LHA

Sizes:

627
637
647
657

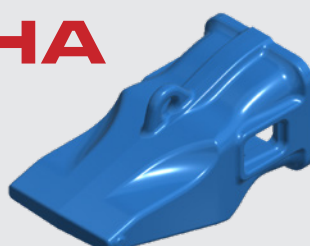

NEW SUPERIOR KS STEEL

Keech has raised the bar again with its new **KS** steel, a game-changing abrasion resistant steel alloy that improves even more on Keech's KF proprietary steel. The new Keech **KS** steel is used throughout Keech's 6-series GET, providing superior hardness and durability, with up to twice the impact strength of competitor products.

- Able to withstand peak/impact loads
- Higher reliability
- Resistant to wear and breakages
- Self sharpening
- Improved wear life
- Increased hardness throughout

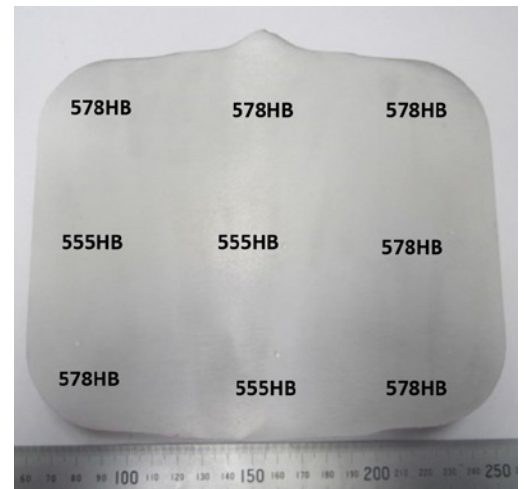

Keech Steels	Hardness	Yield Strength	Tensile Strength
KF Steel	477-514 HB	1250 MPa	1400 MPa
KS Steel	514-601 HB	1550 MPa	1740 MPa

MACHINE BREAK OUT FORCE

KEECH 6-series GET	Lip size (mm)	Hydraulic hoe (kN)		Wheel loader (kN)		Hydraulic face shovel (kN)	
		STD.HD	XHD	STD	XHD	STD.HD	XHD
627	90	546	424	972	772	625	487
637	100	751	582	1335	1060	858	667
647	120	896	694	N/A	N/A	1024	796.5
657	140	1093	846	N/A	N/A	1249	971

WHY CHOOSE KEESHARP™

SAVES MONEY

- ✓ Reduced maintenance cost
- ✓ Better bucket penetration

SAVES TIME

- ✓ Fast changeout time
- ✓ Increased reliability

BOOSTS PRODUCTIVITY

- ✓ Increased safety
- ✓ Increased production

**PROVEN
BENEFITS**



CONTACT INFORMATION

Bendigo Foundry, 30-46 Powell Street, Bendigo Victoria 3550

Email Orders.bendigo@derwentindustries.com.au

Visit www.derwentindustries.com.au

Speak to our team today: Call 1300 453 324



Global-Mark.com.au®



Global-Mark.com.au®



Global-Mark.com.au®